

**SCHEDA RICHIESTA PREVENTIVO TESTE PER MACCHINE CNC**  
**INQUARY FORM FOR HEADS TO BE USED WITH MACHINING CENTER**

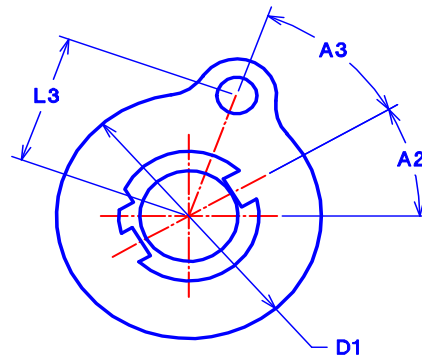
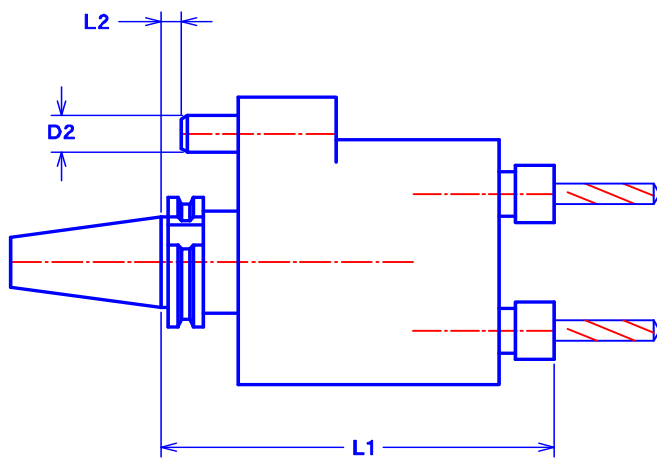
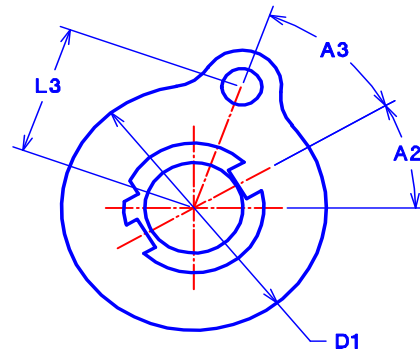
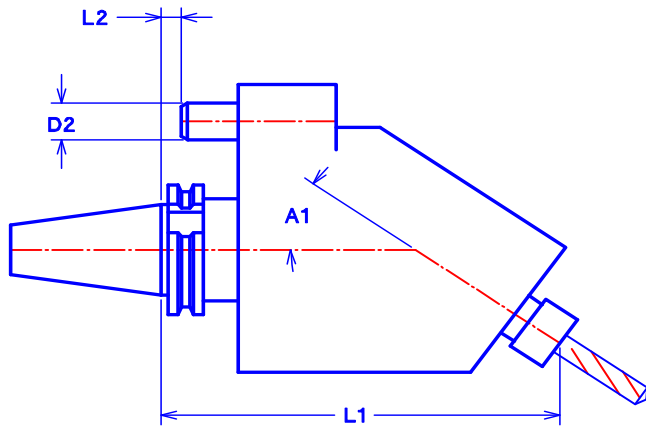

Cono  
Shank

DIN 69871

CAT

BT

HSK

Grandezza  
Size

30

40

45

50

63

80

100

A1

A2

A3

D1 max

D2

L1 max

L2

L3

Peso max  Kg  
max Weight