

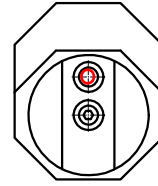

TESTE REGISTRABILI CON MANDRINI DIN 55058
ADJUSTABLE MULTI SPINDLE HEADS WITH SPINDLES DIN 55058

Tipo / Type 115M
Codice / Code 111220.100
Interasse / Range 0-64



Tipo / Type 115
Codice / Code 111215.100
Interasse / Range 37-165

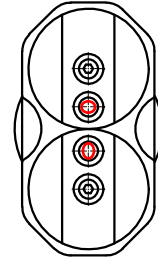

Tipo / Type 119
Codice / Code 111218.100
Interasse / Range 79-207

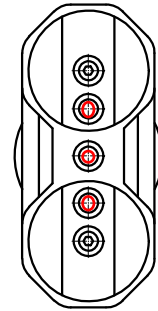

Tipo / Type 116
Codice / Code 111216.100
Interasse / Range Ø53-Ø181

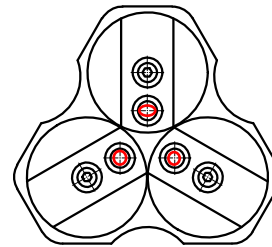

Tipo / Type 117
Codice / Code 111217.100
Interasse / Range Ø79-Ø207

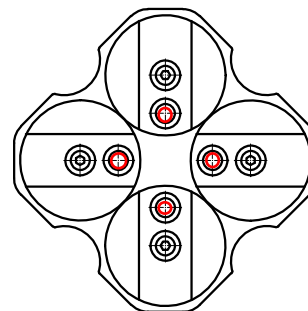

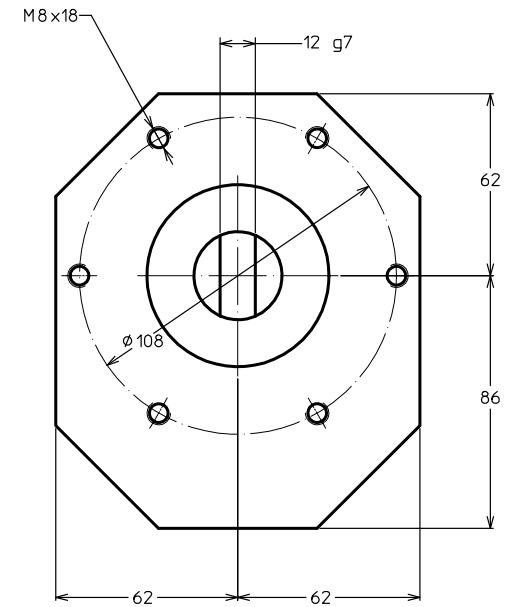
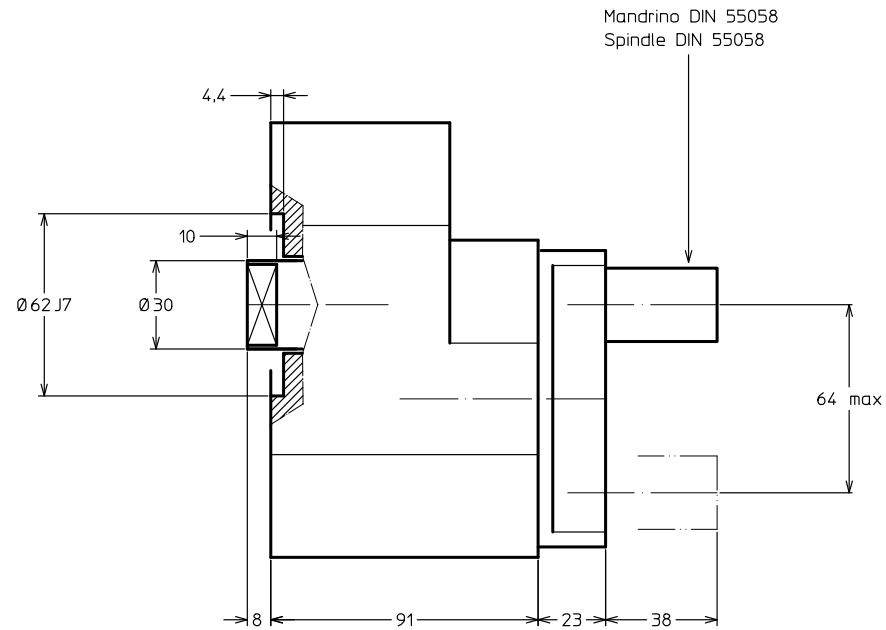
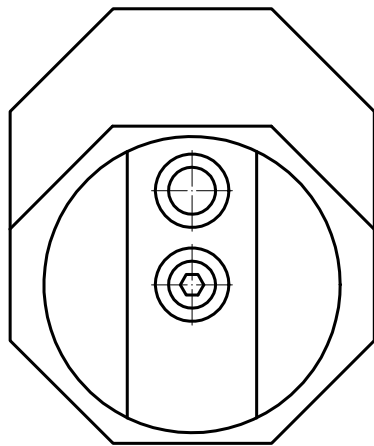

TESTA A 1 MANDRINO REGISTRABILE TIPO 115M / 1 SPINDLE ADJUSTABLE HEAD TYPE 115M

SPECIFICHE TECNICHE / TECHNICAL SPECIFICATION

Modello / Type	115M
Codice / Code	111220.100
Foratura max / Max drilling	Ø 14
Rapporto di trasmissione / Transmission ratio	1:1
Velocità max / Max speed	2500 RPM
Peso / Weight	4.4 Kg

ACCESSORI / ACCESSORIES

Flangia di collegamento / Quill clamp
Trascinatore / Driver
Giunto / Joint

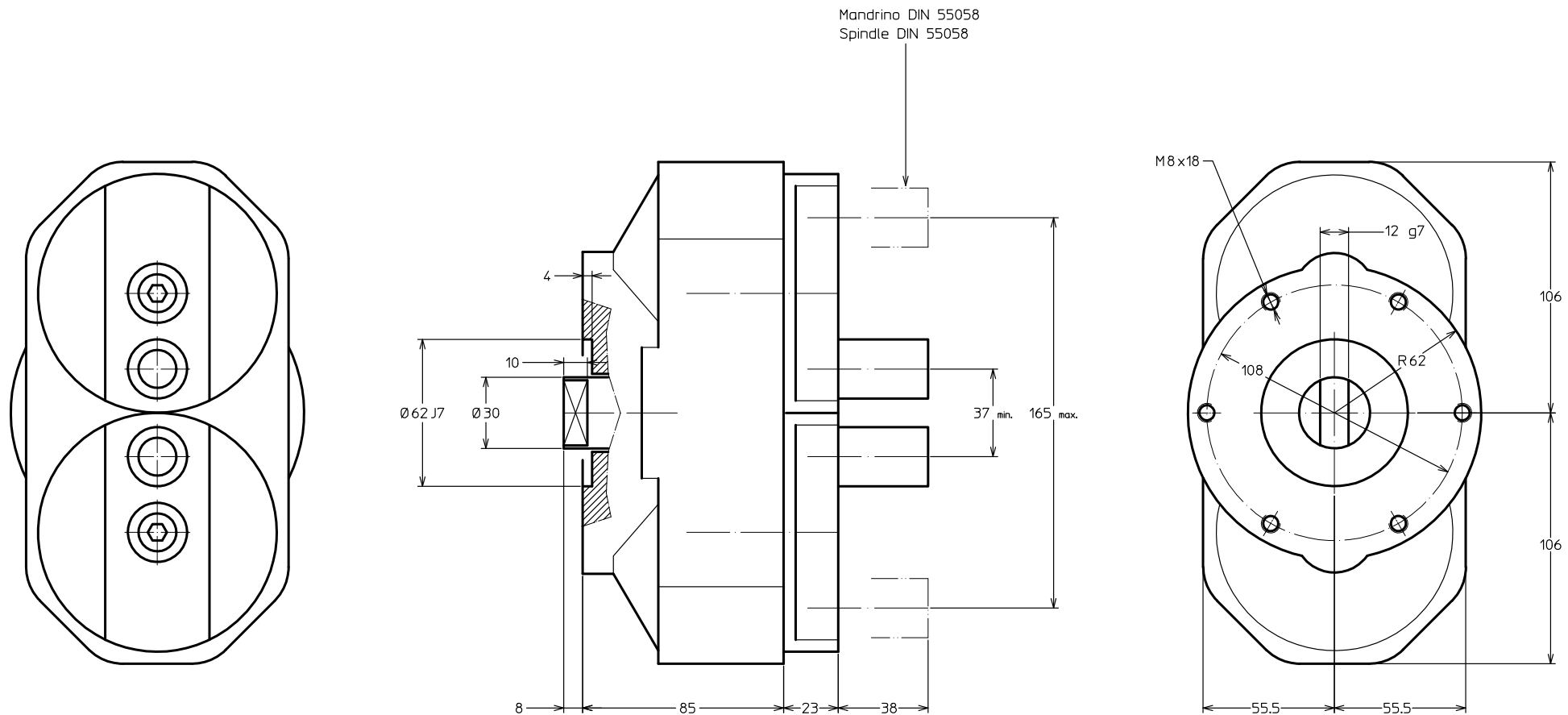

TESTA A 2 MANDRINI REGISTRABILE TIPO 115/ 2 SPINDLE ADJUSTABLE HEAD TYPE 115

SPECIFICHE TECNICHE / TECHNICAL SPECIFICATION

Modello / Type	115
Codice / Code	111215.100
Foratura max / Max drilling	Ø 14
Rapporto di trasmissione / Transmission ratio	1:1
Velocità max / Max speed	2500 RPM
Peso / Weight	6.3 Kg

ACCESSORI / ACCESSORIES

Flangia di collegamento / Quill clamp
Trascinatore / Driver
Giunto / Joint

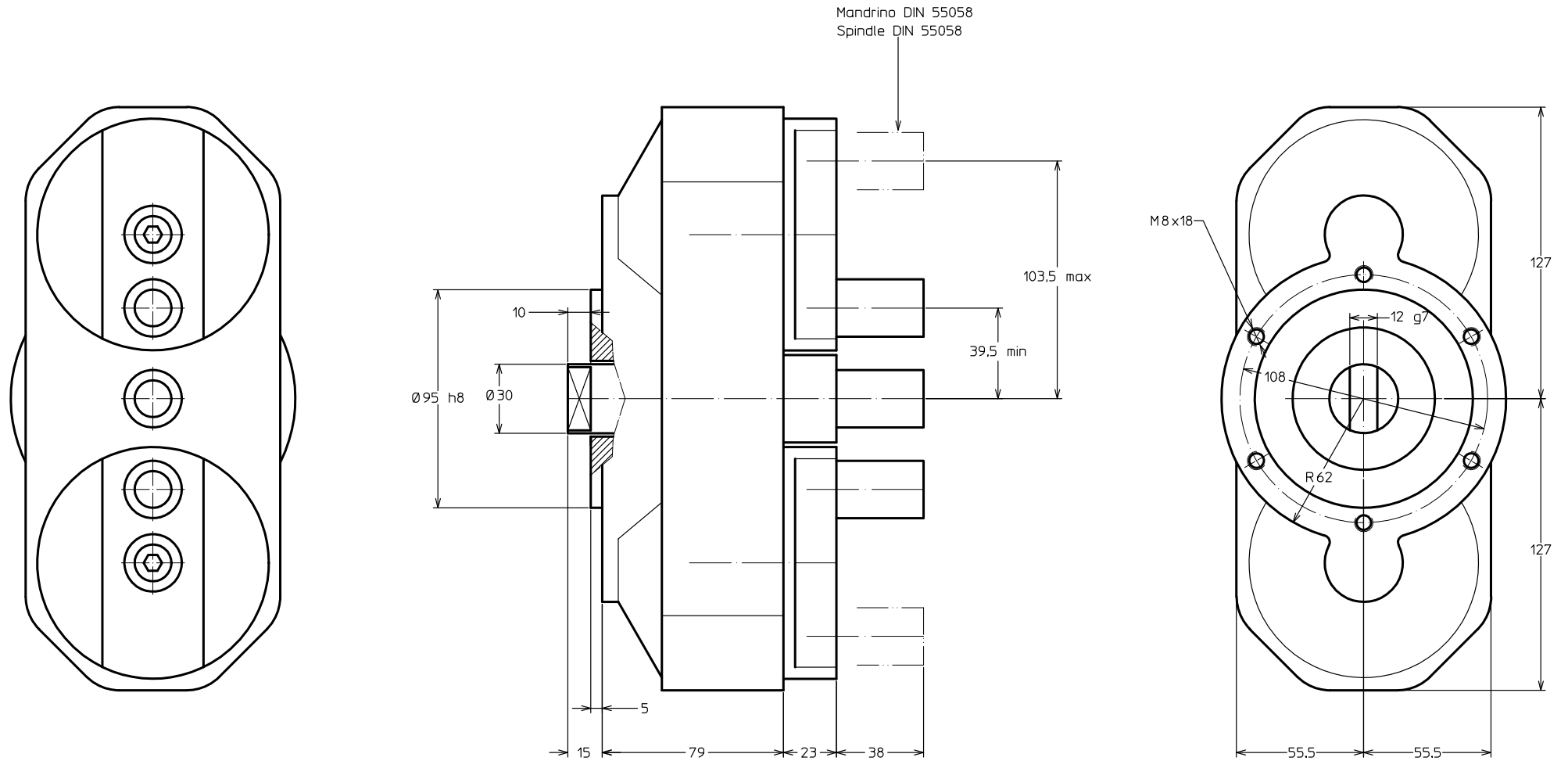

TESTA A 3 MANDRINI REGISTRABILE TIPO 119/ 3 SPINDLE ADJUSTABLE HEAD TYPE 119

SPECIFICHE TECNICHE / TECHNICAL SPECIFICATION

Modello / Type	119
Codice / Code	111218.100
Foratura max / Max drilling	Ø 14
Rapporto di trasmissione / Transmission ratio	1:1
Velocità max / Max speed	2500 RPM
Peso / Weight	7.7 Kg

ACCESSORI / ACCESSORIES

Flangia di collegamento / Quill clamp
Trascinatore / Driver
Giunto / Joint

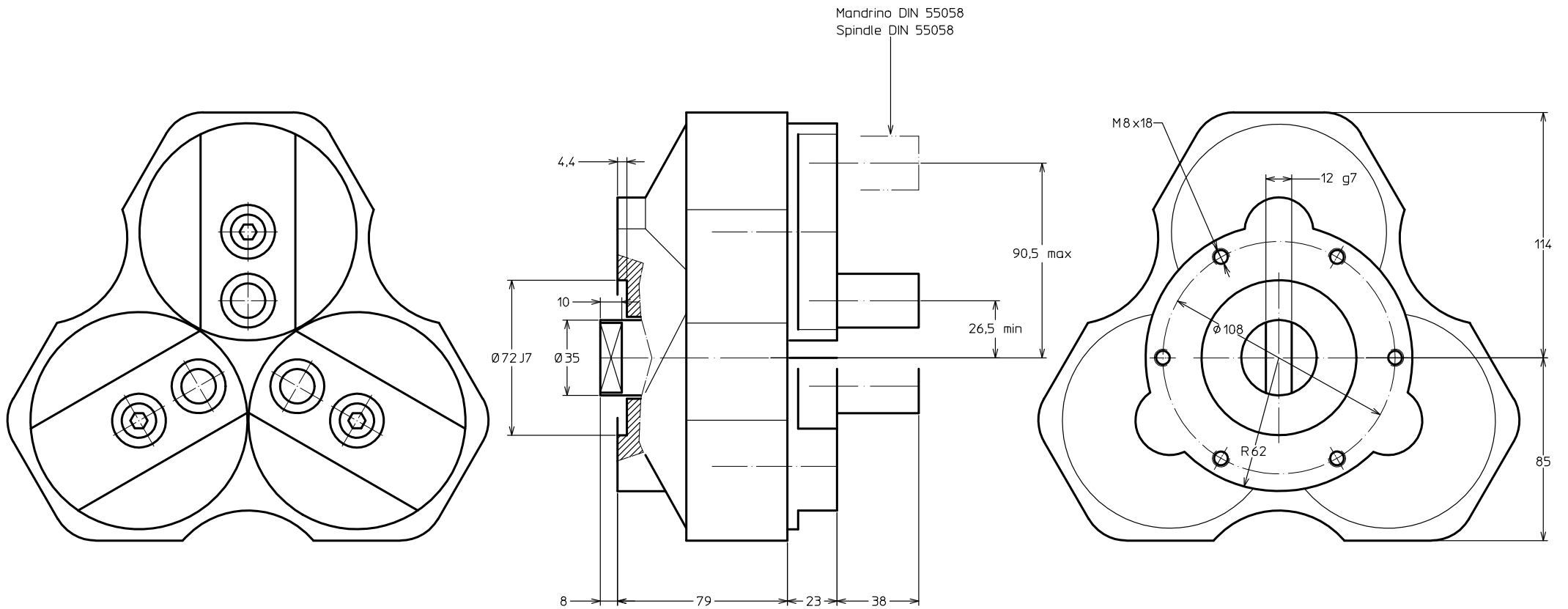

TESTA A 3 MANDRINI REGISTRABILE TIPO 116/ 3 SPINDLE ADJUSTABLE HEAD TYPE 116

SPECIFICHE TECNICHE / TECHNICAL SPECIFICATION

Modello / Type	116
Codice / Code	111216.100
Foratura max / Max drilling	Ø 14
Rapporto di trasmissione / Transmission ratio	1:1
Velocità max / Max speed	2500 RPM
Peso / Weight	9.2 Kg

ACCESSORI / ACCESSORIES

Flangia di collegamento / Quill clamp
Trascinatore / Driver
Giunto / Joint

Mandrino DIN 55058
Spindle DIN 55058

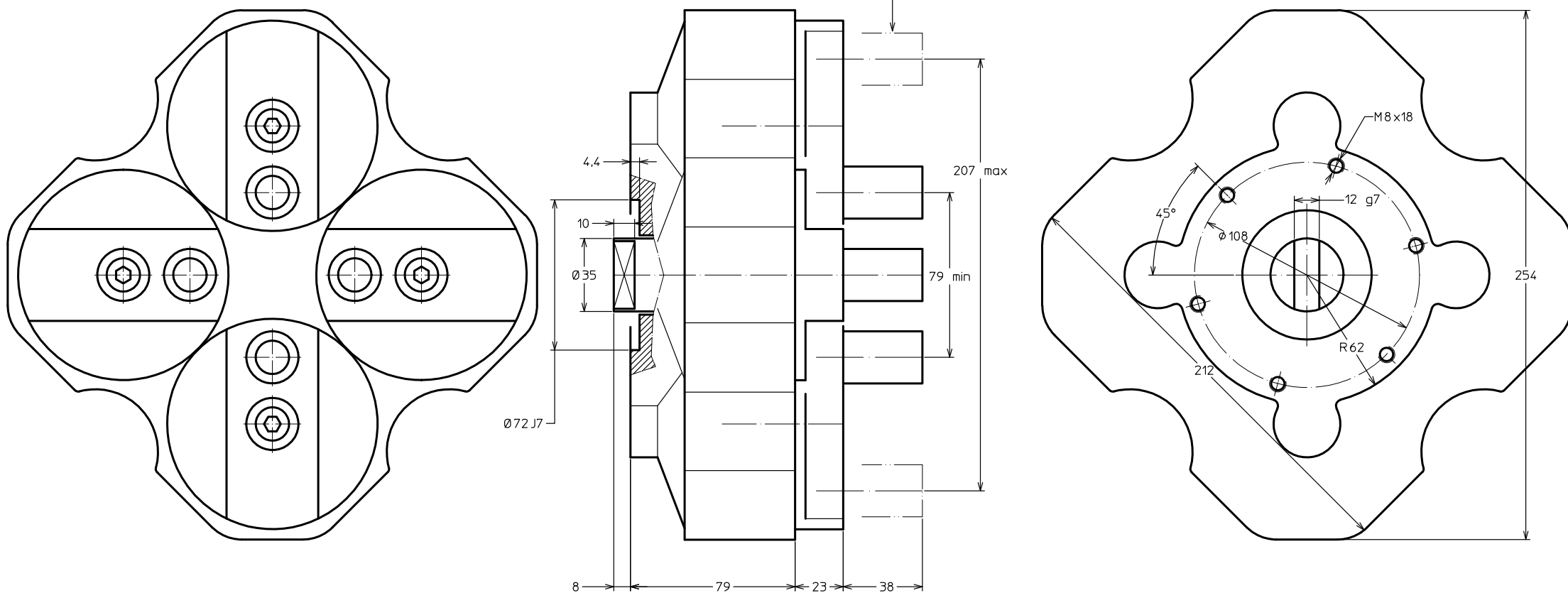

TESTA A 4 MANDRINI REGISTRABILE TIPO 117/ 4 SPINDLE ADJUSTABLE HEAD TYPE 117

SPECIFICHE TECNICHE / TECHNICAL SPECIFICATION

ACCESSORI / ACCESSORIES

Modello / Type 117
 Codice / Code 111217.100
 Foratura max / Max drilling \varnothing 14
 Rapporto di trasmissione / Transmission ratio 1:1
 Velocità max / Max speed 2500 RPM
 Peso / Weight 12.2 Kg

Flangia di collegamento / Quill clamp
 Trascinatore / Driver
 Giunto / Joint